

Deluxe Multi-function Massage Chair

RT7720  
USER MANUAL

Please read all instructions carefully before using.



## ▶ **PRODUCT SPECIFICATIONS**

---

Name: Deluxe Multi-function Massage Chair

Model: RT7720

Rated Voltage: 220V~

Rated Frequency: 50Hz

Rated Power: 180W

Safety Design: Class I

Thank you for purchasing this product. Please read this user manual carefully before using to ensure proper operation.

Please keep this USER MANUAL properly for future reference.

## ▶ **CONTENTS**





---

SAFETY INFORMATION .....	1
NAME AND FUNCTION OF EACH COMPONENT .....	3
External Structure .....	3
Internal Structure .....	3
Remote Control .....	4
Remote Control Instructions .....	5
Display Screen Menu Instructions .....	6
BLUETOOTH CONNECTION .....	12
CENTER CONSOLE INSTRUCTIONS .....	13
PRELIMINARY CHECKS .....	14
Installation Methods .....	14
Installation Site .....	17
Floor Protection .....	18
Best Circumstances .....	18
Grounding .....	18
Commissioning .....	19
After Operation .....	19
Move Method .....	20
Connect to Power .....	20
CARE AND MAINTENANCE .....	21
TROUBLE SHOOTING .....	22
PRODUCT SPECIFICATIONS .....	22

## ▶ SAFETY INFORMATION

### Safety Information

- ▶ Read all warnings carefully before use.
- ▶ Precautions and warnings listed below will help to ensure proper use of this appliance.
- ▶ The classes of accidents caused by incorrect use are classified into “WARNING” and “CAUTION”, Read all warnings below and follow all instructions within this manual.

 <b>WARNING</b>	Improper operation may cause injury to users.
 <b>CAUTION</b>	Improper operation may cause users injury or product damage.
 Prohibited	 No Disassemble

### Not Suitable For Below Persons

We recommend that those with any of the following conditions should consult your physician before using.

 <b>WARNING</b>	<ul style="list-style-type: none"> <li>◆ Those who are using electronic medical instrument embedded in the body, such as cardiac pacemaker.</li> <li>◆ Those undergoing treatment, especially those who are not feeling well.</li> <li>◆ Those with malignant tumors or malignant abscesses.(Need to be supervised)</li> <li>◆ Women who are pregnant or menstruating.</li> <li>◆ Those with osteoporosis or fracture spine.</li> <li>◆ Those with skin disease or those whose skins are injured.</li> <li>◆ Those with high fever.</li> <li>◆ Close supervision is necessary when this product is used by, on, or near children, invalids, or disabled persons.</li> </ul>
--	---

### Controller Precautions

 <b>CAUTION</b>	<ul style="list-style-type: none"> <li>◆ Do not operate the controller or pull the controller cable with damp hand.</li> <li>◆ Do not spill water or other liquid onto the controller to avoid fault.</li> <li>◆ Do not lay heavy staff on the controller.</li> </ul>
--	---

### Cautions Regarding The Ac Adapters And Ac Cord

 <b>CAUTION</b>	<ul style="list-style-type: none"> <li>◆ Check that the power voltage stated on the rating label corresponds to your local electricity supply.</li> <li>◆ Do not use a damp hand to unplug the AC cord to avoid electric shock.</li> <li>◆ Do not pull on the AC cord,reach to the front end to unplug it.</li> <li>◆ Do not squeeze the AC cord by the appliance or other heavy objects.</li> <li>◆ Do not damage,over bend , pull hard, twist or tie the power cord.</li> <li>◆ If the supply cord is damaged, it must be replaced by the manufacturer or its service agent or a similarly qualified person in order to avoid a hazard.</li> </ul>
--	--

## ▶ TROUBLE SHOOTING

No.	Symptoms	Possible Causes	Possible Solutions
1	Noise is heard while in use.	This sound is normal and comes from the massager rubbing against the cloth cover.	No need to take any measures.
2	Massage Chair does not start.	The power cord is not secured into the socket.	Insert the power plug properly into the massage chair .
		Power switch is off.	Turn on the switch.
		The fuse is blown.	Replace only with a fuse of same type and rating.
3	No music from the speaker after the Bluetooth is connected.	The volume is turned to the lowest.	Adjust the speaker volume from the mobile devices
4	Backrest or legrest can not raise or recline.	Excessive load pressed on the backrest or legrest.	Relieve the load and try again.
5	Airbag malfunction.	The air hose is blocked.	Straight the air hose and clear out the blockage.

If problem remains, please contact the dealer for maintenance.

Tip:Do not attempt to repair this product yourself,our company shall not be liable for the injury or damage caused by any servicing without authorization.

## CARE AND MAINTENANCE

### Care and Maintenance Instructions

- ▶ To treat stains on back panel, armrest, footrest, plastic parts or air hose, spot clean with mild detergent foam, then wipe it with a dry cleaning cloth.
- ▶ To treat stains on controller, power box, spot clean with a dry cleaning cloth.
- ▶ To treat stains on back cushion or pillows, use a water-based upholstery cleaner only, wipe it with moist cloth, then air dry.
- ▶ To clean the foot/calf unit covers, remove it from the chair, hand wash with a mild detergent, then line dry.

#### CAUTION

- ▶ Pull out the power cord from the power strips before care and maintenance. To avoid electrical shock or injury, do not touch the power cord with wet hands. Make sure no detergent enters into the power box while cleaning.
- ▶ Do not use benzene, thinner or other solvents on your product, it may cause fading or damage to the product.
- ▶ Do not iron the upholstery.

### Storage Methods

- ▶ Keep the product free from dust. Cover the product with a dust-free cloth to prevent collection of dust if not in use for a long period of time.

#### CAUTION

- ▶ Do not leave this product exposed to direct sunlight for long periods of time. This may cause fading or damage.

### Warm Tips

During daily use, please check for the following symptoms:

- ▶ Burnt smell.
- ▶ The product experiences unusual power ON/OFF when touching the power cord.
- ▶ Hot power cord.
- ▶ Other abnormal symptoms.

#### CAUTION

- ▶ Please stop using the product to avoid breakdowns or accidents if any above symptom spotted.
- ▶ Switch off the power button and disconnect the plug, contact the local distributors or supplier for repair.
- ▶ All other servicing except above care and maintenance should be serviced by an authorized dealer or service center.

#### WARNING





Pull out the power cord from the power strips before care and maintenance. To avoid electrical shock or injury, do not touch the power cord with wet hands. Do not try to dismantle or repair the product yourself, please send your massage chair to the authorized service center.

## SAFETY INFORMATION

### Best Circumstances

 CAUTION	<ul style="list-style-type: none"> <li>◆ Do not use this appliance where temperature is over 40°C.</li> <li>◆ Do not use this appliance in humid or dusty environment, or when any part of the body is in contact with plumbing or any similar ground. Keep the air openings free of lint, hair, and the like.</li> <li>◆ Unplug from outlet during thunder or lightning storms, and before putting on or taking off parts.</li> <li>◆ Do not use outdoors.</li> <li>◆ Please place the product on the flat level floor.</li> <li>◆ Do not store near heat or open flame.</li> </ul>
--	--

### Best Practices For Safe Use

 CAUTION	<ul style="list-style-type: none"> <li>◆ Only for users weighs below 120kg.</li> <li>◆ Use this product only for its intended use as described in this manual.</li> <li>◆ Do not use the product for therapeutic treatment purpose.</li> <li>◆ Appliance should only be used by one person, do not use by two or more persons at the same time to avoid damage to the products.</li> <li>◆ Do not use the product right after meal, it may cause discomfort.</li> <li>◆ Remove the accessories from the arms and empty the pockets while use the massage services.</li> <li>◆ Check the upholstery under the cushions and other spots, if any damages are present, do not use it and refer to a qualified service professional for servicing.</li> <li>◆ If you feel any abnormal discomfort during the operation of this product, turn off the power immediately and do not use the product.</li> <li>◆ Use the appliance for 20 minutes each time is highly recommended</li> <li>◆ Make sure there is no obstacles behind the chair and there is enough clearance before adjusting the backrest or legrest angle.</li> <li>◆ Make sure no other excessive load pressed on the backrest or legrest besides the user.</li> <li>◆ Make sure there is no children, pets or other objects under the backrest or legrest.</li> <li>◆ Please be seated properly while using the appliance.</li> <li>◆ Do not drag or push the chair or roll on its caster on wood floor or carpet to avoid damage.</li> </ul>
 PROHIBITED	<ul style="list-style-type: none"> <li>◆ Never operate this product if it has damaged /exposed parts or power leakage.</li> <li>◆ Do not stand on or stack heavy objects on the footrest.</li> <li>◆ Children should be supervised to ensure that they do not play with the massage chair.</li> <li>◆ Do not fall into sleep while the product is operating.</li> <li>◆ Avoid using the product under the influence of alcohol.</li> <li>◆ Do not put hands or fingers in any openings of the appliance to avoid injury or damage to the appliance.</li> <li>◆ If there is any smoke or unusual smell while using, stop using immediately, unplug the power cord.</li> </ul>
 NO DISASSEMBLY	<ul style="list-style-type: none"> <li>◆ Do not disassemble this product yourself to avoid failure.</li> <li>◆ Do not dismantle, fix or modify the yourself, Please contact authorized dealer or service agent.</li> </ul>
 UNPLUG THE POWER CORD	<ul style="list-style-type: none"> <li>◆ Pull out the power cord from the power strips before maintenance. Never plug-in or pull out power cord with damp hand, to avoid shock or injury.</li> <li>◆ Pull out the power cord from the power strips while not in use.</li> <li>◆ Unplug from outlet when the power supply is cut, switch all controls to off.</li> </ul>

## ▶ NAME AND FUNCTION OF EACH COMPONENTS

### External Structure

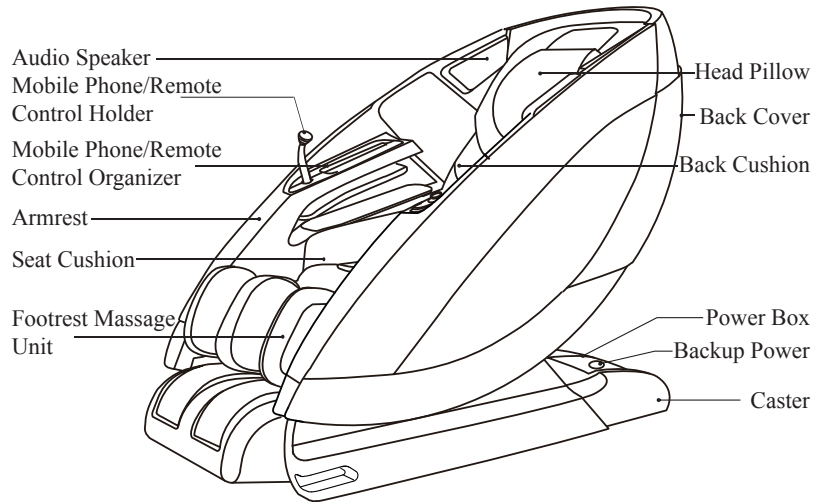

### Internal Structure

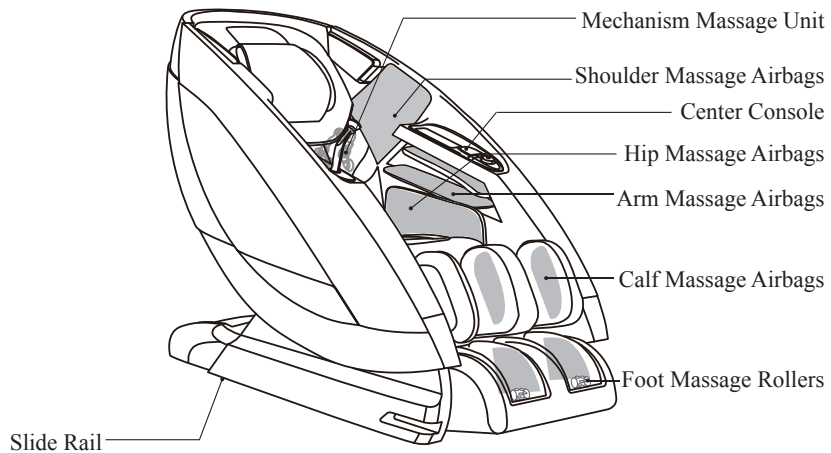

## ▶ PRELIMINARY CHECKS

### Move Method

- ▶ Roll the chair on its casters to the desired location.
- ▶ Incline the backrest to upright position.
- ▶ Turn off the power switch and unplug the appliance from the electrical outlet.
- ▶ Using two people, push down on the backrest and lift up on the front side by grabbing the moving Holder located to the front bottom of the armrest, roll the chair on its casters to the desired location (check the sketch for reference)

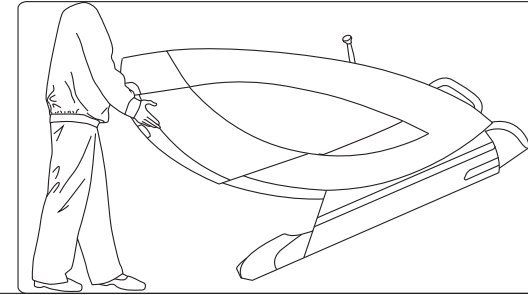

### ⚠ CAUTION

- ▶ Do not move the chair when there is user inside.
- ▶ To carry this product, do not lift by the footrest or armrest, hold the chassis and steady the backrest (have 4 or more people to carry the product)

### Connect to Power

- ▶ Connect this appliance to a 3-wire properly grounded outlet.
- ▶ Turn on the power switch located at the back of power box.

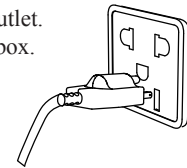

### ⚠ CAUTION

- ▶ Please verify that there is no damage to the supply cord before switching on the massage chair.
- ▶ Please verify that the main power switch is turned off before connecting to power.

## ▶ PRELIMINARY CHECKS

### Commissioning

- ▶ Use the remote control to recline the backrest to its lowest position, raise and extend the footrest to its top position, make sure there is enough clearance before commissioning.
- ▶ Return the backrest and footrest back to its default position after commissioning and turn off the power switch. To choose the massage program, please check the Instructions of Remote Control and Instructions of Display Screen for reference.

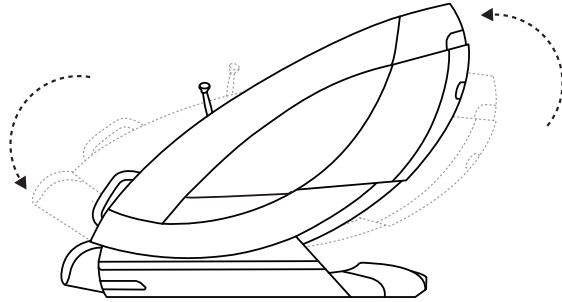

### ⚠ CAUTION

- ▶ Do not take seat while the footrest is lifted.
- ▶ Do not put excessive load on the footrest to avoid damage.

### After Operation

- ▶ Always unplug the massage chair from the electrical outlet immediately after using.
- ▶ Put the Remote Control into the Remote Control Pocket.
- ▶ Turn off the power switch and unplug the massage chair from the electrical outlet while not in use to avoid children power on the massage chair accidentally.
- ▶ When not in use of a long period of time, we recommend that the chair be covered, the power cord be coiled and that the unit be placed in an environment free of dust and moisture.

## ▶ NAME AND FUNCTION OF EACH COMPONENTS

### Controller

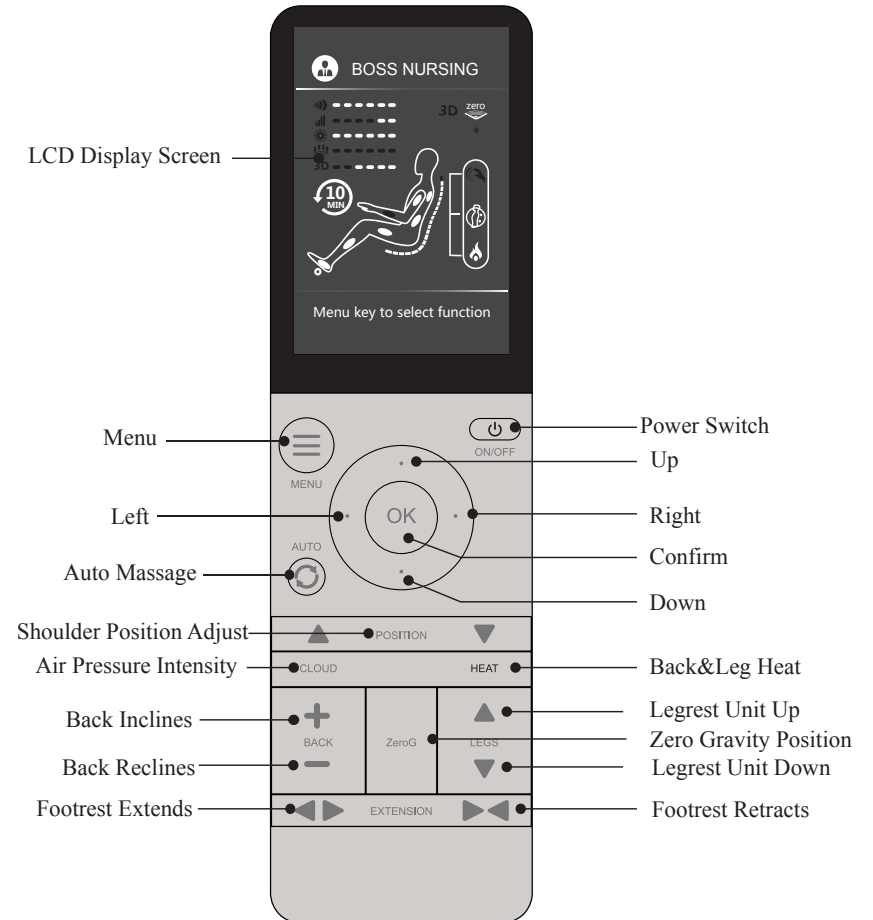

## ▶ NAME AND FUNCTION OF EACH COMPONENTS

### Remote Control Instructions



**Power:** Press this button to power on/off the remote control.

▶ Press this button while connect to power to show the menu display, the LCD Screen lights up.

▶ Press this button again to stop massage or turn off the product.



#### Menu

▶ Display AUTO, MEDITATION, 4D PROGRAM, MANUAL, CLOUD TCH, SOUND SOOTHE and SETTINGS.



POSITION

**Shoulder Position Adjust (slightly adjust mechanism up/down the shoulder)**

▶ Press and hold on Position UP/DOWN button to adjust the rollers to the desired position while under MANUAL or MEDITATION-ZONE/SPOT massage mode.

▶ Press and hold on Position UP/DOWN button to adjust the rollers to the desired position while under the body scan procedure.



#### Auto Program

▶ Display the AUTO mode menu. Press this button to toggle among the AUTO programs where users can choose among 7 massage categories named TENSION RELIEF, YOGA STUDIO, PERFORMANCE, FULL BODY, UPPER BODY, LOWER BODY and DEMO according to their body status and time of day. The active program displays at the top of the status screen. (Check the Display Menu for detailed information)



#### Navigation

▶ 1. While under MENU display, use the UP/DOWN/LEFT/RIGHT buttons to navigate the screen, press OK to select.

▶ 2. While massage program is running, press UP/DOWN buttons to navigate the parameters, press LEFT/RIGHT buttons to adjust, press OK to select.

HEAT

#### Back&Legs Heat

▶ Press this button to turn on/off Back&Legs Heat, it defaults to medium level heat.

CLOUD

#### Air Pressure Intensity

▶ While airbags is working, press this button to adjust air pressure intensity.

ZeroG

#### Zero Gravity Position

▶ Press to position the chair in Zero Gravity Position, the Zero Gravity Position icon will be lit on display screen; press again to close the Zero Gravity Position, the Zero Gravity Position icon will be off.

▶ At such a weightless position that the height of the legs slightly higher than the upper body, the weight of body can evenly distributed throughout, reducing the pressure of the spine and joints both physically and mentally.



LEGS

#### Legrest Unit Up

▶ Press and hold to raise the legrest; release the button to stop.



#### Legrest Unit Down

▶ Press and hold to lower the legrest; release the button to stop.

## ▶ PRELIMINARY CHECKS

### Floor Protection

▶ We recommend to place a piece of carpet or soft mat underneath it to avoid damaging the floor.

We recommend to place a piece of carpet or soft mat underneath it to avoid damaging the floor.

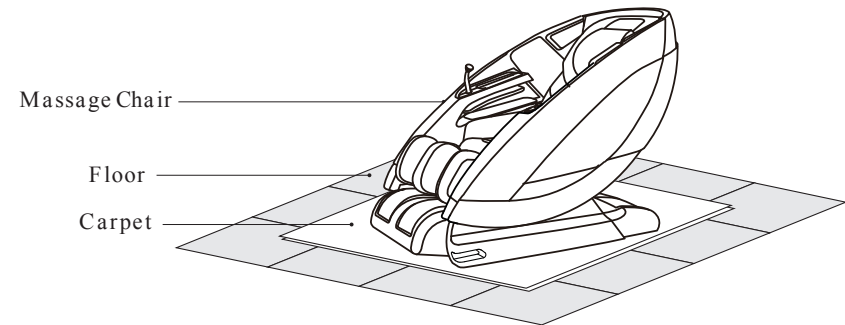

### Best Circumstances



Do not use the massage chair in high moisture environment such as near swimming pool or bathroom to prevent electric shock accident.



Please keep the massage chair away from heated surfaces to prevent fire hazard or damage to the product.

### Grounding



This product must be grounded, the plug must be plugged into an appropriate 3-wire grounded outlet that is properly installed and grounded in accordance with all local codes and ordinances to reduce risk of electrical shock.



## PRELIMINARY CHECKS

### Installation Site

#### Clearance space for the massage chair:

- ▶ Ensure there is an adequate clearance for the installation:
  - It needs 10cm clearance for the recline of the backrest;
  - It needs 60cm clearance for the raise and extension of the footrest;
  - Make sure there is 10cm clearance behind the backrest and 60cm clearance in front of the footrest.
- ▶ Keep it 1 meter away from the TV, radio or other audio&video appliance to avoid signal interference.

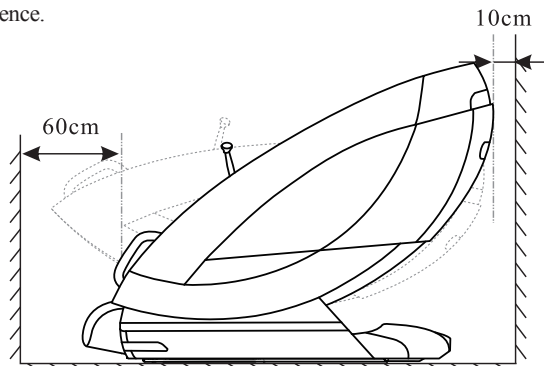

- ▶ Keep the distance between the power socket and power switch within 1.5 meter.

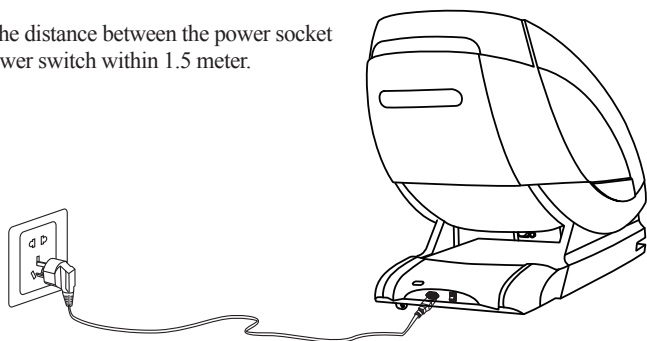

### CAUTION

- ▶ Keep the distance between the power socket and power switch within 1.5 meter to avoid damage of power cord while massage chair sliding forward.
- ▶ Straighten the power cord while in use to avoid tangle or damage.
- ▶ When the massage chair sliding forwards or back, please check to make sure there is no children, pets or other obstacles around to avoid accident. Straighten the power cord while in use to avoid tangle or damage.

## NAME AND FUNCTION OF EACH COMPONENTS



### Back Inclines

- ▶ Press and hold to raise the backrest; Release the button to stop.

### Back Reclines

- ▶ Press and hold to recline the backrest; Release the button to stop.



### Footrest Extends

- ▶ Press and hold to extend the footrest; release the button to stop. (Make sure there is no obstruction in advance)



### Footrest Retracts

- ▶ Press and hold to retract the footrest; release the button to stop.



### WARNING

- ▶ After using, press Power button to restore the chair; press any button on the remote control to stop the restoration; press Power button again for further operation.

## Display Screen Menu Instructions

### ▶ Auto Program

Press to display the Auto Program menu, press this button to toggle among 7 massage categories named TENSION RELIEF, YOGA STUDIO, PERFORMANCE, FULL BODY, UPPER BODY, LOWER BODY and DEMO. Use navigation buttons to toggle among the subprograms, Press OK to enter the program you desire. Selected program will show on the home screen.

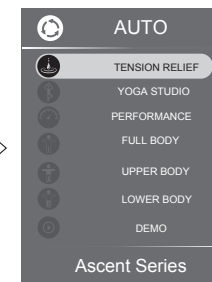
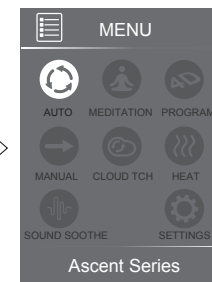
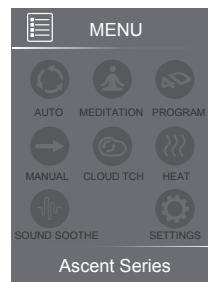

- ▶ **TENSION RELIEF:** Wake up your body and set the tone for the entire day.
- ▶ **YOGA STUDIO:** Stretch and soothe your body from head to toe.
- ▶ **PERFORMANCE:** Enhance physical functioning with high performance massage.
- ▶ **FULL BODY:** Focus on relieving sore and tension in the neck and shoulders.
- ▶ **UPPER BODY:** Focus on relieving sore and tension in upper body.
- ▶ **LOWER BODY:** Focus on relieving sore and tension in lower body.
- ▶ **DEMO:** A quick show of massage chair's features and functions.

## NAME AND FUNCTION OF EACH COMPONENTS

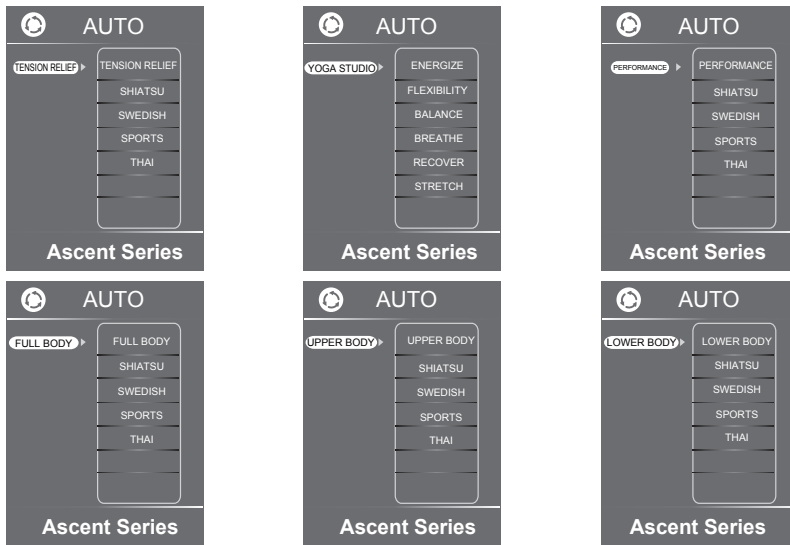

### ► 4D Massage

Press 4D PROGRAM from MENU display to show the 4D PROGRAM display, press RIGHT button then press UP or DOWN button to navigate among: SHIATSU, SWEDISH and STRETCH.

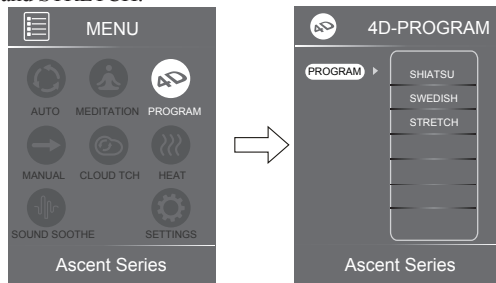

### ► Cloud Touch

**Cloud Touch:** Press CLOUD TCH from MENU display to show the CLOUD TCH display, press RIGHT button then press UP or DOWN button to navigate between FOCUS-Air pressure region and INTENSITY-Air pressure intensity, Press OK button to enter the setting you desire.

**Focus-Air pressure region:** Press FOCUS from CLOUD TCH display, press RIGHT button then press UP or DOWN button to navigate among: FULL, ARM&SHOULDER, BACK&WAIST, LEG&FOOT, BUTTOCK air pressure positions and OFF (deactivate airbag intensity function). Press OK button to enter the air pressure you desire.

## PRELIMINARY CHECKS

### Step 4: Other Accessories

- Connect the power cable to the product power socket located at the power box of the product. (Check below illustration for reference)
- Switch ON the power located at the back of power box, raise the backrest of the product to fully upright position.

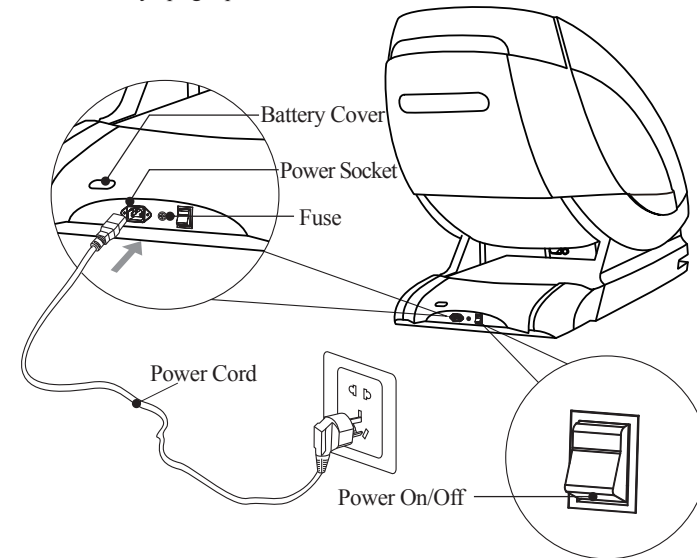

- After the installation of all accessories, plug the power cord into a well grounded three cord socket, switch on the power, use the remote control to start the operation. (Check above illustration for reference)

### Step 5: Install Backup Power Batteries

- Prepare 4 pieces of 9V batteries.
- Remove the battery cover, insert batteries properly, ensuring that the + (plus) and - (minus) terminals are aligned correctly, press the unit electrode on top and put the battery back.

### 😊 Tips

- In the event of a power outage or emergency, backup power batteries provide much needed power to restore backrest and legrest unit. We suggest to replace the batteries after the 5th time of use.

## PRELIMINARY CHECKS

### Step 3: Install Remote Control Holder

- ▶ Remove the rubber cover in front of organizer, insert the lower end of remote control holder into the socket.

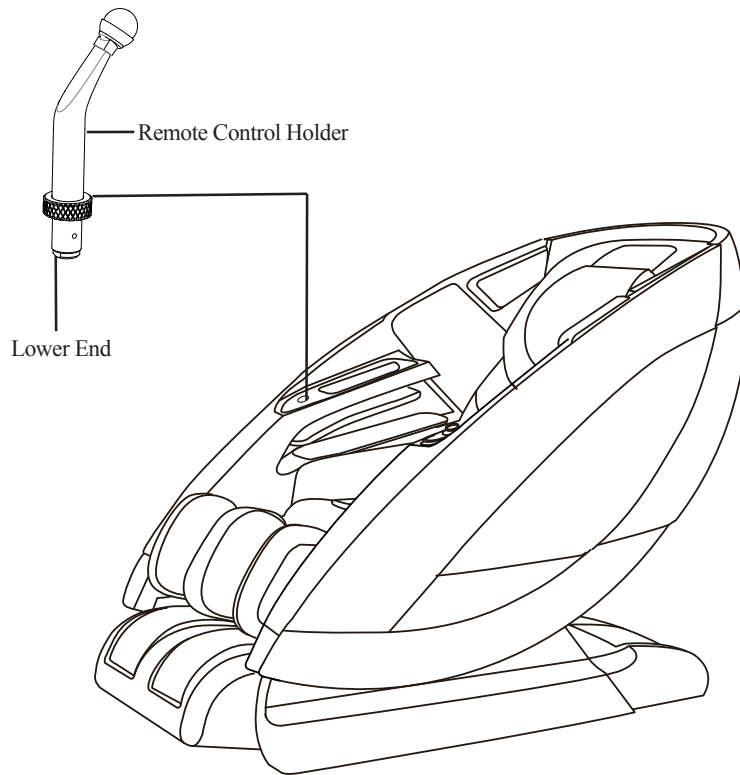

## NAME AND FUNCTION OF EACH COMPONENTS

**Intensity-Air pressure intensity:** Press INTENSITY from CLOUD TCH display, press RIGHT button then press UP or DOWN button to navigate among: LOW, 2, 3, 4, HIGH air pressure, press OK button to enter the airbag setting you desire. Air pressure intensity can only adjust when CLOUD TCH is working.

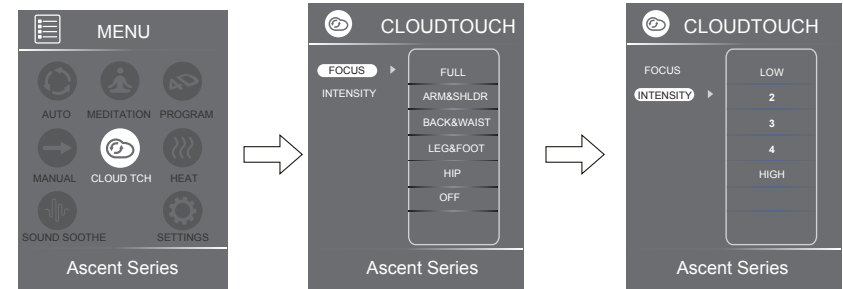

### ▶ Manual Program

Press MANUAL from MENU display, press UP or DOWN button to navigate among: MODE, FOCUS, WIDTH, and SPEED.

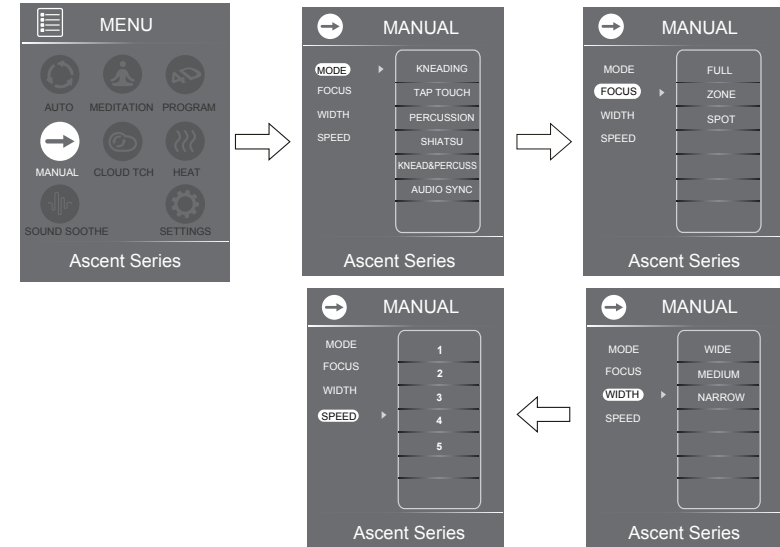

**Massage Mode:** Press MODE from MANUAL display, press RIGHT button then press UP or DOWN button to navigate among: KNEADING, TAP TOUCH, PERCUSSION, SHIATSU, KNEAD&PERC, and AUDIO SYNC. Press OK button to enter the setting you desire. Selected mode will show on the home screen.

## ▶ NAME AND FUNCTION OF EACH COMPONENTS

**Back Mechanism Massage Focus:** Press FOCUS from MANUAL display, press RIGHT button then press UP or DOWN button to navigate among: FULL, ZONE and SPOT. Press OK button to enter the setting you desire.

**Back Mechanism Massage Width:** Press WIDTH from MANUAL display, press RIGHT button then press UP or DOWN button to navigate among: WIDE, MEDIUM and NARROW mechanism roller width. Press OK button to enter the setting you desire. Selected width will show on the home screen.

**Back Mechanism Massage Speed:** Press SPEED from MANUAL display, press RIGHT button then press UP or DOWN button to navigate among: level 1, 2, 3, 4, 5 Mechanism massage speed. Press OK button to enter the intensity level you desire.

### ▶ Heat-Back&Leg Heat

**Back Heat:** Press HEAT from MENU display to show the HEAT display, press RIGHT button then press UP or DOWN button to navigate among: LOW, MEDIUM, HIGH heat level, or OFF (deactivate heat function). Press OK button to enter the heat setting you desire.

**Leg Heat:** Press HEAT from MENU display to show the HEAT display, press RIGHT button then press UP or DOWN button to navigate among: LOW, MEDIUM, HIGH heat level, or OFF (deactivate heat function). Press OK button to enter the heat setting you desire.

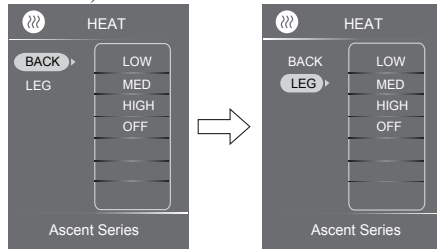

### ▶ Sound Soothe

Press SOUND SOOTHE from MENU display to show the SOUND display, press RIGHT button then press UP or DOWN button to navigate among: NATURE, BROOK, SPRING SHOWER, SEASIDE, CALM RAIN, TWILIGHT, SUMMER STORM and WIND CHIME. Press OK button to enter the sound you desire.

**Volume:** Press VOLUME from MENU display to show the VOLUME display, press RIGHT button then press UP or DOWN button to navigate among: MUTE, MIN, 2, 3, 4, and MAX. Press OK button to enter the volume you desire.

**Tips:** To play sound, please make sure the Bluetooth is ON and the speaker is not muted.

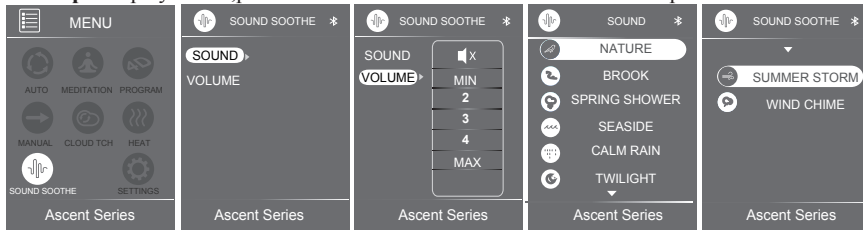

## ▶ PRELIMINARY CHECKS

### Installation Methods

#### Step 1: Take All Massage Chair Units Out of the Cartons

- ▶ Unpack the cartons: take out all upholstery unit, accessories out of the cartons.
- ▶ Before beginning installation, please verify that all components are included (check with the packing list carefully).

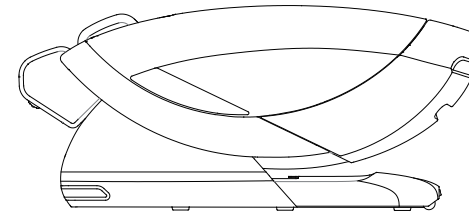

#### Step 2: Install Remote Control Unit

- ▶ Take the remote control unit out of the accessories box;
- ▶ Connect the remote control cable to the massage chair's port, then tighten the screw cap clockwise to secure the connector in place. (Check the illustration below for reference)

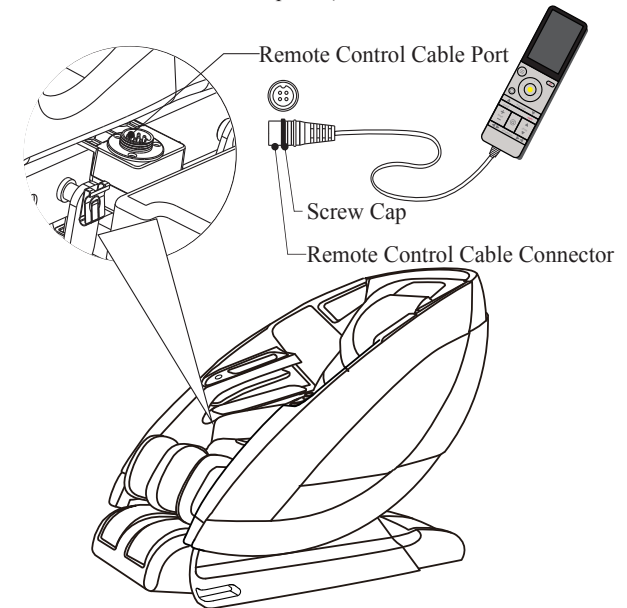

## CENTER CONSOLE INSTRUCTIONS

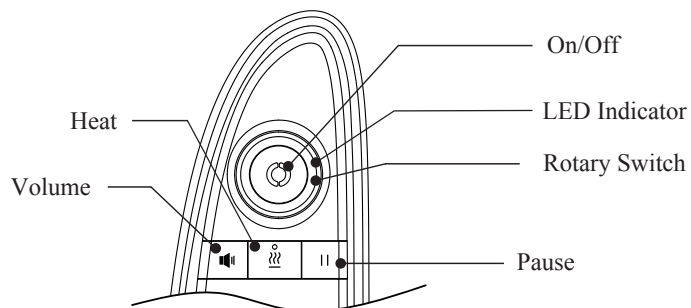

### On/Off: Turn On/off the Massage Chair

- ▶ While massage chair is under sleep mode, press this button to wake it up, remote control display screen lights up.
- ▶ Another short press on this button will turn on TENSION RELIEF massage program (same conditions apply to running auto/manual programs).
- ▶ While massage chair is running, press and hold on this button for 3 seconds to restore; while massage chair is restoring, a short press on this button will stop the restoring, massage chair goes into sleep mode.

### Rotary Switch: Press to incline/recline backrest or adjust sound soothe/demo music volume.

- ▶ While volume indicator lights off, rotate clockwise to incline backrest, rotate counterclockwise to recline backrest; While volume indicator lights up, rotate clockwise to turn up sound soothe/demo music volume, rotate counterclockwise to turn down sound soothe/demo music volume;

LED Indicator: While massage chair is working, LED Indicator displays blue; While it's restoring/standing by, LED Indicator glowing green; While it's sleeping, LED Indicator is off;

### Volume: Activate/Deactivate Volume Control Function of Rotary Switch

- ▶ Press to activate volume control function of rotary switch, red indicator lights up, rotate clockwise, rotate clockwise to turn up sound soothe/demo music volume, rotate counterclockwise to turn down sound soothe/demo music volume;
- ▶ Press again to deactivate volume control function of rotary switch, red indicator lights off, rotate clockwise to incline backrest, rotate counterclockwise to recline backrest;

### Heat: Turn On/off Back&Legs Heat.

- ▶ Press to turn on Back&Legs Heat, red indicator lights up, it defaults to medium level heat; press again to turn off Back&Legs Heat, red indicator lights off.

### Pause: Pause Massage Chair Function

- ▶ Press to pause massage chair function, red indicator lights up; press again to continue, red indicator lights off.

## NAME AND FUNCTION OF EACH COMPONENTS

### Settings

1. Press SETTING from MENU display to enter SETTING display, press UP or DOWN button to navigate among: INTENSITY, TIME, KNEE, STRETCH, BLUETOOTH, LANGUAGE, FOOT SPD, and BEEP.
2. **Intensity:** Change the 3D Massage protruding (SOFT, 2, 3, 4, STRONG, SOFT is default).
3. **Time:** Set massage timer (10, 20, 30 minutes, 10 minutes is default).
4. **Knee:** Press and hold on Up to move upper leg upwards, release to stop. Press and hold on Down to move upper leg downwards, release to stop. Press Auto Glide On to switch Off/on legrest auto glide&stretch function. When Auto Glide On displays on the screen, the auto glide is turned off.
5. **Stretch:** Press to show stretch display (DOWN, OUT, OFF). Press OFF to turn off stretch function in a certain auto program. Press DOWN to set downwards stretch; Press OUT to set outwards stretch;
6. **Bluetooth:** Turn On/off Bluetooth.
7. **Language:** Set Display Language (English, Chinese, Korea, Vietnamese).
8. **Foot Speed:** Set Foot Roller Speed (SLOW, MEDIUM, FAST, OFF).
9. **Beep:** Turn On/Off Beep (it defaults to On). While beep is on, remote control will beep to report notification.

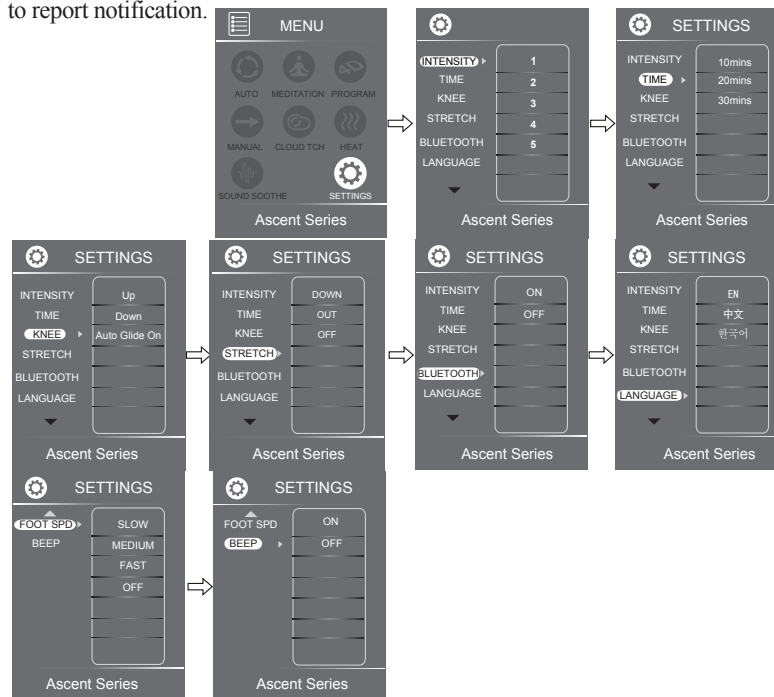

## ▶ NAME AND FUNCTION OF EACH COMPONENTS

### Tips:

1. In the process of Auto or Manual Setting, LCD screen will auto revert back to the homescreen after 10 seconds if there is no operation entered into the remote control. (Check below illustration for reference)

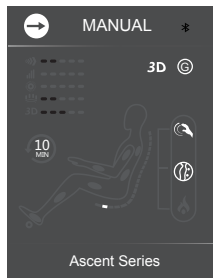

Homescreen display with the Manual program running

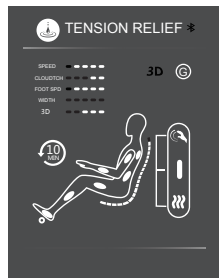

Homescreen display with the Auto program running

### 😊 Tips:

- ▶ While program is running, press twice MENU button to revert to homescreen.
- ▶ While message program is running, press UP/DOWN buttons to navigate the parameters, press LEFT/RIGHT buttons to adjust, press OK to select.
- ▶ Press Auto button to select auto massage program.

2. Mechanism will scan shoulder position before first time running of Auto Program (check the right figure), it will start to run the desired auto program right after the completion of scanning.

**Tips:** Scanning shows on display screen when mechanism starts running.

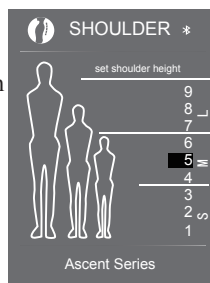

### ⚠ CAUTION

- ▶ Do not disassemble this product yourself to avoid product failure.
- ▶ Make sure no water or other liquid enters into the remote control to avoid fault.
- ▶ Do not pinch or squeeze the remote control or power cord.

## ▶ BLUETOOTH CONNECTION

3. Press the ON/OFF button to end the Auto Program and reset the massage chair.

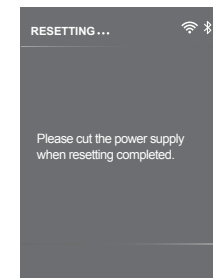

Instructions on Connecting audio to the massage chair speakers via Bluetooth (Android/Apple ios)

- ▶ On your Android/Apple iOS device, go to Settings > Bluetooth and turn on Bluetooth. Place your massage chair in discovery mode and wait for it to appear on your Android/Apple iOS device. Choose RT7720 to pair, when it displays Bluetooth connected, it's set to go.

### ⚠ CAUTION

- ▶ The massage chair power and the Bluetooth need to be set to On while pairing.
- ▶ If the pairing failed, try to connect again.

### Configuration Requirement

- ▶ Tablet PC and Smart phone must have Bluetooth function.
- ▶ Android system version need to be above 4.0.