

# **RK7803 Navigator**

## **Zero-gravity Space Capsule Massage Chair**

### **Operation Manual**

*Make your life healthy  
and beautiful every day!*



**Please keep this manual in a safe place for future reference.**

# RK7803 Navigator Zero-gravity Space Capsule Massage Chair Introduction

1. Unique 3D Massage Chair. The soft intelligent 3D back massage machine can provide a very gentle and comfortable massage to your shoulder, neck and waist like a real professional massage therapist. It also has a unique shoulder pressing function.
2. Automatic Body Detection Function. With this feature, the machine can determine different body heights and customize the travel length of the mechanism on your back.
3. Automatic Adjustment. The backrest, seat and leg-rest can be separately adjusted by automatic electric actuators to move into a relaxed zero-gravity pose, which raises the feet above the head and improves the blood circulation of the brain with stimulated oxygenation. The armrest can move backward or forward simultaneously along with the backrest.
4. New Capsule Built-in Air Pressure Massage. The chair offers built-in air bag massage for both arms combined with additional air bag massage in the seat, the legs and the feet while in zero-gravity pose providing you with a relaxed feeling throughout your entire body.
5. Extendable/Retractable Leg-rest. This feature makes the chair suitable for people in different heights. Newly added rollers in the foot-rest can give a very fantastic rolling massage to your feet, relaxing the fatigue of your feet.
6. Remote Control with the Big Colorful High-Definition VFD. The VFD can show the parts of body, massage technique and massage status simultaneously.
7. Innovative Air Pressure Design. The air bags in the seat and bottom back areas can offer stretching, turning and waist twisting massage on corresponding points.
8. Built-in Mp3. The Mp3 allows for broadcasting music through either the speakers or earphone using U disc, SD card or MMC card. The incorporation of music into massage technique will improve the massage effect and relieve your psychological pressure.
9. Heating Function in Bottom Back.
10. Head Massager with air pressure function. This feature can help relieve the fatigue and release the pressure of brain.
11. Unique Body Stretch Function. This feature can fully stretch your body.

## Navigator Zero-gravity Space Capsule Massage Chair



- ✦ 1. RK7803 Navigator Zero-gravity Space Capsule Massage Chair.
  - 2. Please read the manual carefully before using.
  - 3. Keeping the manual in safe place for your reading in at any time.
  - 4. Please pay attention to "Safety Instruction".
- ✦ We reserve the right for design modification. It is subject to change without notice. The pictures in this manual are for reference. Please refer to the actual product.

### Content





<b>Preparation</b>	Attention for safety -----	1
	External structure parts -----	5
	Internal structure parts -----	6
	Schematics of mechanical parts -----	7
	Mechanical parts list -----	8
<b>Installation</b>	Installation -----	9
<b>Massage Operation</b>	The adjustment before massage -----	14
	Remote control usage method -----	16
	Operation instruction & function illustration -----	20
	What is needed to do after finishing massage -----	22
<b>Maintenance</b>	Clean and maintenance -----	23
<b>Miscellaneous</b>	Troubleshooting analysis -----	24
	Technical data -----	25

Please keep this manual in a safe place for future reference.

- ✦ Please read this manual carefully for installation to operate the massage chair in correct way.
- ✦ "Safety Instruction" is provided in both warning and caution for important safety information





 <b>Warning</b>	This sign indicates "warning of causing possible death, hurt to body".
 <b>Caution</b>	This sign indicates "caution of causing possible hurt, damage to things".

### Symbol meaning

	This sign indicates "forbidden behavior"		This sign indicates "self disassembly is forbidden"
	This sign indicates "must follow instruction to operate"		This sign indicates "correct operation way for cable"

- ✦ This sign indicates "correct operation way for cable"

## Warning

	<ul style="list-style-type: none"> <li>● Osteoporosis patient;</li> <li>● People with heart problems including embedded pacemaker or other medical electronic device inside the body;</li> <li>● For pregnant women or people not in good health, please consult doctor before operation;</li> <li>● Children or drunk people are not allowed to use the chair;</li> <li>● Please don't sleep in the chair.</li> </ul>	People who are not suitable to use the chair
	<ul style="list-style-type: none"> <li>● Make sure there are no children or pets or other objects around (under, behind or in front of) the chair at the moment of backrest, leg-rest up/down or leg-rest retraction/extension from reclining position.</li> <li>● During operation, if you feel abnormal please stop the operation to consult your physician.</li> <li>● Please do no over massage the head.</li> <li>● Don't over massage the belly or knees and be careful when massaging the neck area.</li> <li>● Children or pets are not allowed to play on the chair especially during massage. Standing or sitting on the back or armrest is also not allowed.</li> <li>● People who move about difficultly or can't express themselves must be taken care of strictly and continuously during massage.</li> <li>● When massage the back, better unzip the small waist cushion and remove it.</li> </ul>	Accident / Injury
	<ul style="list-style-type: none"> <li>● Insert the plug of the chair into correct and suitable power socket.</li> <li>● Make sure the plus is completely inserted into the socket to reduce short circuit or fire risk.</li> <li>● Unplug the power if not in use, stop all massage function and turn off on/off key before unplugging.</li> </ul>	Fire and electric shock
	<ul style="list-style-type: none"> <li>● Massage cushions of the chair are not to be folded for storage.</li> <li>● Power cord, plug, socket can't be used in broken or loose contact condition.</li> <li>● Don't use other electric power except rated voltage in case of fire, electric shock or any breakdown.</li> <li>● Any broken, re-process, knotted, twisted power cord or pressed under heavy cargo is not allowed to use.</li> </ul>	Accident Fire and electric shock
	<ul style="list-style-type: none"> <li>● If the chair works dysfunctional, or is broken, splashed with water or falls into water, please have it repaired by professional repairman or send the chair to assigned service agent, self-modification, disassembly or maintenance is forbidden.</li> <li>● If power cord or plug is damaged, please don't replace it by yourself, please contact us or appointed dealer for replacement.</li> <li>● To avoid electric shock or body hurt, please don't open or disassemble any part of the chair, there is not any attached part of the chair for maintenance by customers.</li> <li>● Check if leather or cloth material on the back and other areas is broken or not, if broken, no matter how small it is, please stopping using the chair, unplug the power and have it repaired.</li> </ul>	Disassembly and maintenance



## Caution

!	<ul style="list-style-type: none"> <li>Please operate the chair in a flat or level place.</li> </ul>	To avoid sudden falling.	
	<ul style="list-style-type: none"> <li>Position the chair 40cm from the wall to allow for sufficient space to recline up and down.</li> </ul>	To make sure the back lying.	
	<ul style="list-style-type: none"> <li>The maximum suggested operating time is 20mins. 5mins for each position beginning with the slight-step massage. A long continuous massage in the same position may cause an uncomfortable feeling.</li> </ul>	Too long time massage is bad for your body.	
	<ul style="list-style-type: none"> <li>Before sitting on the chair to avoid injury please inspect everything to confirm that the massage heads are in the correct position.</li> </ul>	To avoid accidental injury.	
	<ul style="list-style-type: none"> <li>Please make sure that the power switch is at the "OFF" position before inserting the plug into the socket.</li> </ul>		
	<ul style="list-style-type: none"> <li>Turn off all controls before removing plug from outlet.</li> </ul>	To avoid the accident when turn on the power	
	<ul style="list-style-type: none"> <li>Make sure the plug completely insert into the socket</li> </ul>	To reduce short circuits and any fire hazard.	
<ul style="list-style-type: none"> <li>Checking whether any damage on wire no water, rubbish on wire.</li> </ul>	To avoid electric shock when any leakage or damage.		
<ul style="list-style-type: none"> <li>Installing earth wire in correct way. The plug must be inserted into socket with earth connect. The earth connect couldn't be bend or cut off.</li> </ul> 			
⊘	<ul style="list-style-type: none"> <li>Don't press with hands or step on the massage heads with feet.</li> <li>Don't put hands between the working massage heads.</li> <li>Don't put hands or feet in the gap of mechanical parts.</li> <li>Don't drop or embed anything into the slot of massage chair.</li> <li>Don't stand or sit or put anything on the backrest, armrest or leg-rest.</li> <li>Don't stand on the chair during operation.</li> <li>Don't move the chair during operation.</li> <li>Don't pull out the plug or turn off the power during operation.</li> <li>Don't put your hands or head between leg-rest when in reclining position.</li> <li>Don't use the massage chair while wearing hair curlers.</li> <li>Don't sit or press on the backrest when the chair is in reclining position.</li> <li>Don't massage on exposed skin or with thin clothes. It may cause skin ache.</li> </ul>	To avoid accidents or injury	
	<ul style="list-style-type: none"> <li>Keep the chair away from heat, wet, sharp things and corrosive, inflammable, explosive environment.</li> <li>To use electric blanket or other heating products on the chair is forbidden.</li> </ul>	To avoid fade, discolor on upholstery or hardened, deteriorated on PU.	
			<ul style="list-style-type: none"> <li>Keep chair away from stove or other warming products.</li> <li>Don't put the chair under the sun or other high temperature place.</li> </ul>
	⊘	<ul style="list-style-type: none"> <li>Don't use the chair outside.</li> </ul>	



## Caution

⊘	<ul style="list-style-type: none"> <li>Please don't use or store the chair in the wet environment like near the swimming pool, or bathroom.</li> <li>Keep the chair and remote control dry all the time.</li> <li>Don't use the chair when your body is wet.</li> </ul>	To avoid leakage or electric shock.
	<ul style="list-style-type: none"> <li>Make sure to install the earth wire in correct way (Incorrect install way may cause electric shock. If you don't know how to install, please find a professional electrician)</li> <li>Don't use plug adapter (If the enclosed plug doesn't match with socket, please don't change the plug by yourself and find a professional electrician to install a matched socket.)</li> </ul>	To avoid electric shock.
⊘	<ul style="list-style-type: none"> <li>Unplug the power before cleaning the chair.</li> <li>Unplug the power after using the chair.</li> </ul>	To avoid electric shock or fire hazard.
	<ul style="list-style-type: none"> <li>Unplug the power when any damage on the power.</li> </ul>	
	<ul style="list-style-type: none"> <li>Hold the plug to unplug the power but not try to pull the wire to unplug the power.</li> </ul>	To avoid accidents
⊘	<ul style="list-style-type: none"> <li>Please turn off the power switch and unplug the power after massaging.</li> </ul>	To avoid damage or accidents when power goes back.
	<ul style="list-style-type: none"> <li>Unplug the power immediately when electricity goes off.</li> </ul>	

## Grounding Instruction

- ✦ ※The chair is equipped with a cord having an grounding conductor. The plug must be plugged into an appropriate socket that is properly installed and matched with the plug.

## Replace fuse

- ✦ ※When the fuse is burned out, please turn off the switch and unplug the power. Opening the lid covered the fuse which is located in the switch box. Using a same size fuse to replace the old one, then cover the lid. Or you can find an electrician to replace the fuse.

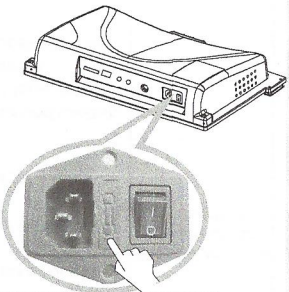

Earth wire is allowed to near these place

Gas pipe: probably cause explosion or fire.  
Phone wire and lightning rod: probably cause electric shock and fire when thundering.  
Water pipe: earth wire is useless where there are plastics

Name of external structure



Preparation

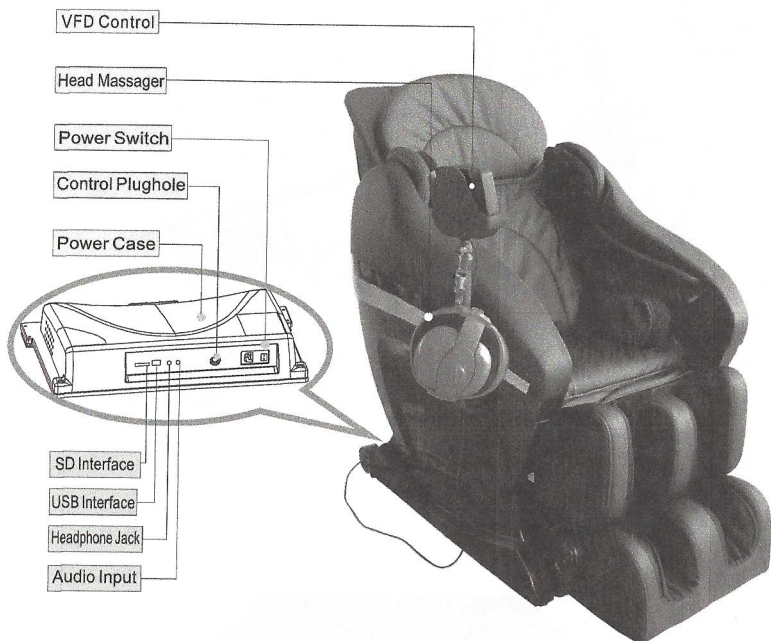

Name of internal structure



Preparation

## Schematics of mechanical parts

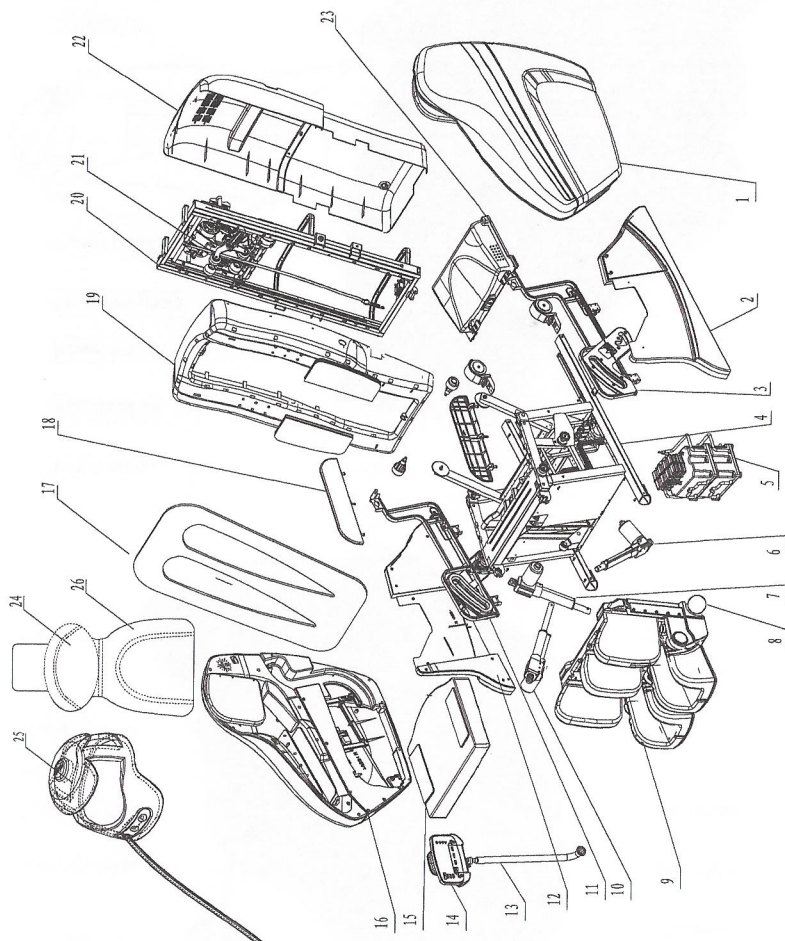

Preparation

## Mechanical parts list

No.	Name	Pc's	No.	Name	Pc's
1	Left armrest assembly	1	22	Back cover	1
2	Left side panel	1	23	Power case assembly	1
3	Left armrest mobile rack	1	24	Pillow	1
4	Seat assembly	1	25	Head Massager Assembly	1
5	Gas case	1	26	Waist Cushion Assembly	1
6	Seat electric actuator	1			
7	Footrest electric actuator	1			
8	Caster assembly	2			
9	Footrest assembly	1			
10	Back electric actuator	1			
11	Right armrest mobile rack	1			
12	Right side panel	1			
13	Controller support bar and holder	1			
14	VFD controller	1			
15	Seat mat assembly	1			
16	Right armrest assembly	1			
17	Back mat	1			
18	Inner armrest panel	2			
19	Back plastomer assembly	1			
20	Back frame assembly	1			
21	RK07 massage machine	1			

Preparation

Installation (1)

Step 1: Unpacking

Take the chair out of the carton box. Take out the head massager, massage chair main body, seat cushion, back cushion, pillow, waist cushion, side air bags of the seat, seat protector pad, remote control, control holder and power cord. It needs at least two persons to move the chair. First cut off the ties binding the armrest rolling glove on its moving support, then use one hand holding the leg rest and the other hand holding the rolling square tube of backrest to take out the chair.

Rolling Glove of Armrest

Plastic Ribbon

Moving Support of Armrest

Head Massager

Back Pad

Waist Cushion and Pillow

Seat Cushion

Seat Protector Pad

VFD Control

Control Holder

Power Cord

Main Body of the Chair

Warning: Do not hold the armrest metal support while removing the chair from the carton. ("DO NOT HOLD" warning sticker is attached)

Warning: Please do not remove the protective white foam cushion located between the backrest and the seat of the chair as this may scratch the leatherette on the back or the footrest.

Warning: Carefully hold the leg rest and rolling upper tube then lift the main body of the chair from the carton and all other materials including the pad, pillow, seat cushion, remote control, remote control holder and the support power cord.

Warning: Do not hold the armrest metal support while removing the chair from the carton. ("DO NOT HOLD" warning sticker is attached)

② Taking two arms from arms box. Catching two sides of the arms and take them out slowly.

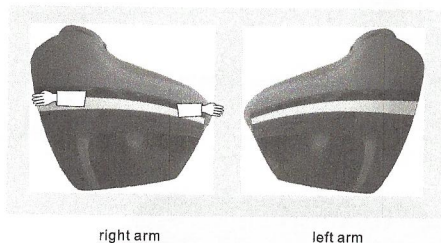

Installation (2)

Step 2: Lifting up the backrest

Slowly lift the backrest up to approximately 120 degrees until you hear a light sound that is locking in the connection. Next connect the left and right metal armrest holder and armrest rolling glove with the enclosed bolt. Connect the metal armrest holder and armrest rolling glove with the bolt. (See Illustration)

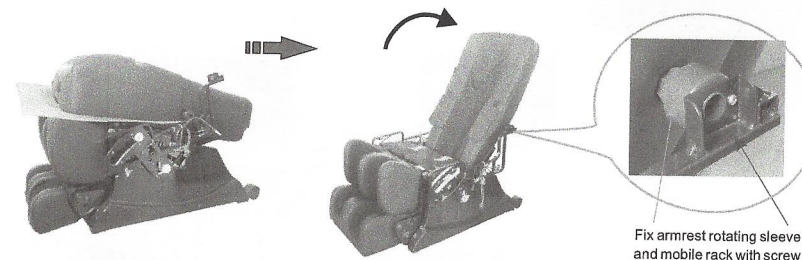

Step 3: Assemble the side air bags and protector pad of the seat.

Side air bags of the seat: 1. Take out the left and right side air bags. Set its leather side toward inside and air pipes behind. Plug the two cylindrical pins in the 2ND and 4TH hole of the seat iron frame. 2. Connect the air pipes from air bags and seat frame together. Note: Grey air pipe of the left air bag should be plugged to the left side of seat frame while the dark brown air pipe of the right air bag should be plugged to the right side.

Seat Protector Pad: Take out the protector pad and plug the cylindrical pins in the 1ST, 3TH and 5TH hole of seat frame. Put the smooth surface of the protector pad inside.

Note: To avoid parts being broken, don't press the pins downwards vertically until you position the pins totally aiming at the holes of seat frame.

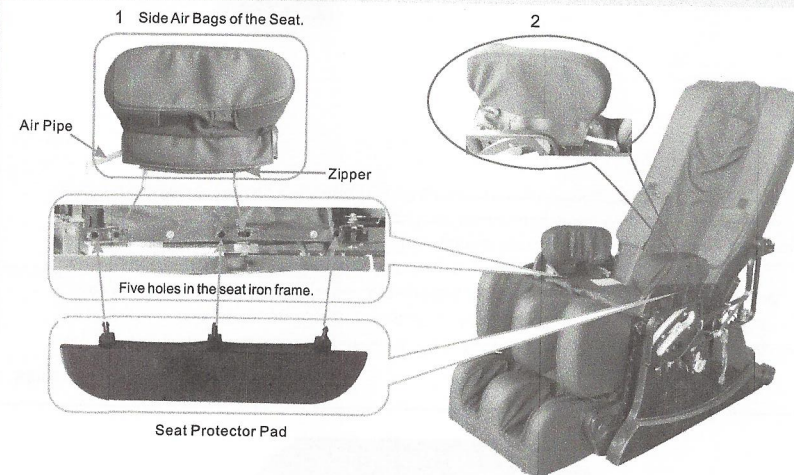

## Installation (3)

## Step 4: Install seat air hoses

Connect black hoses in the seat with same color hoses on the seat frame, make velcro on the seat cushion onto the corresponding part seat frame, zipper the side seat bags and seat cushions.

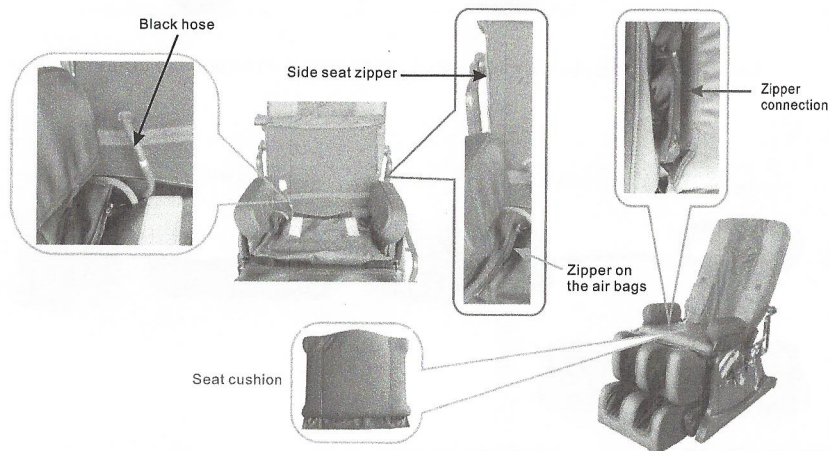

## Step 5 Install back cushion, head pad and movable small pad

1. Connect the back cushion onto the backrest with zippers.
2. Install the head pad on the top of the backrest with velcro.
3. 2 heat plugs go through the 2 housings on the right of the seat cushion, take off hoses on the joints, then freely connect 2 heat plugs on the movable pad and back cushion.

**!** Note: The removable pad with heat function which is zippered on the back must be removed from the back cushion to avoid hurt or accident when the back massage machine is working.

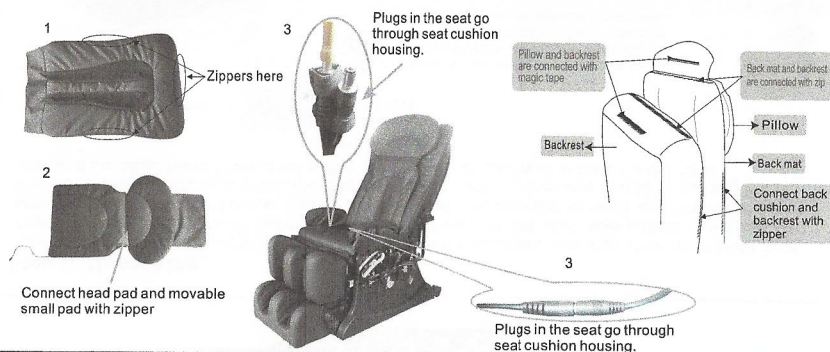

## Installation (4)

## Step 6: Armrest installation

- ① Put locating shaft in the behind of armrest to the hole in mobile rack.
- ② connect the connector with pipe in armrest.
- ③ put the locating shaft to the hole in front of the armrest mobile rack.
- ④ hold the armrest still, and push inside, the installation is finished until you hear "da" sound.
- ⑤ install another armrest following above.

Tips(uninstallation): while pulling tie piece rotating panel behind the armrest by one hand, drag the armrest out of clamp axis by the other; pull out the locating shaft in front of armrest, then loose the connector, pull out the locating shaft behind armrest, uninstillation is done.





Installation (5)

Step 7 Install remote holder, remote control and head massager

1. Install the remote holder onto the right armrest with 3pcs M5\*15 screws, rubber cap should cover screws. Put the remote control into remote holder, remote cable should be put into the clip behind the right armrest.
2. Connect buckle of the head massager with the holder's buckle and hang head massager on the holder.
3. Open head pad, connect outer short hose of the head massager with brown hose on the top of the backrest, long hose of head massager with black hose on the top of the backrest.

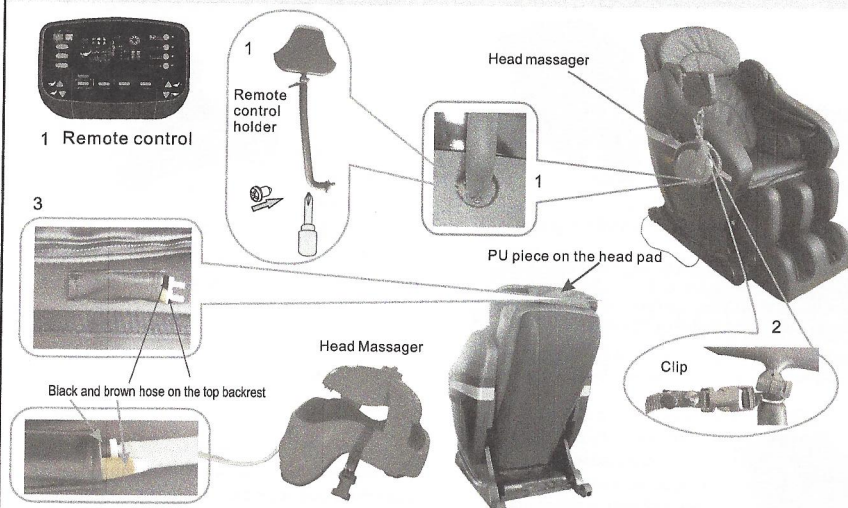

Step 8: Final installation

1. Insert the remote control plug and power plug into the connection hole of the power case located under the backrest. (See Illustration)
  - a. Hole is for the remote control plug
  - b. Hole is for the power plug
  - c. d. When using the headset earphones insert the earphone plug into the hole provided. (See Illustration)
  - e. Insert the USB connection into the hole
  - f. Insert the SD or MMC card reader into the disc drive.
2. Insert the additional power plug of power cable into the socket
3. Turn on the power (power switch "0/1" then press 1 and the light turns on)
4. Use the remote control to choose massage function and enjoy the comfortable massage

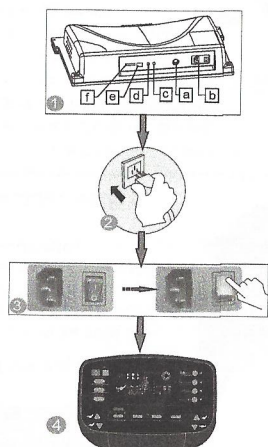

Environment

Caution

- Don't use near swimming pool or bath room and other wet place to avoid leakage and electric shock.
- Don't use under sunlight or near stove and other heating place to avoid upholstery deteriorated.
- Please using chair in flat place to avoid chair falling or noise or other unnecessary trouble.

Checking areas before chair

Checking the area when back and leg extended, make sure no people, pet or other things.

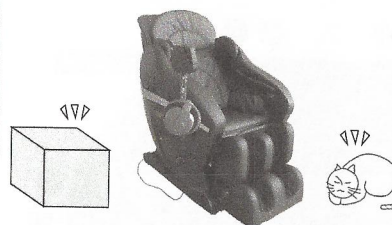

Checking power cable, plug

1. Cleaning the dust on plug on time (using dry cloth).
2. No damage, re-do, bend, stretch, tie or press with heavy thing (especially can't be pressed by the chair) on power cable

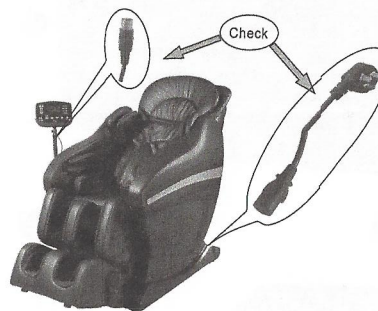

Checking environment

Space size for using the chair

- At least 40cm from back to wall.



- At least 40cm in front of the leg.

Checking surroundings

When back reclining, leg reclining, leg extended and moving seat, pay attention to:

1. Checking any person or things in every direction.
2. Checking the space size.

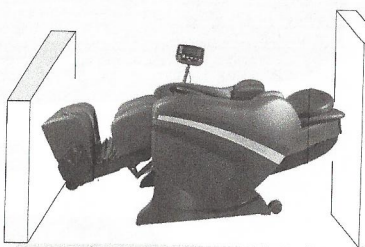
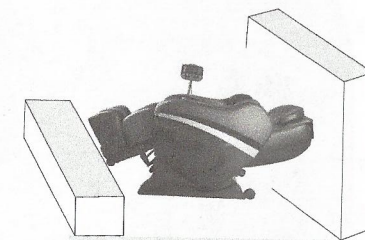

How to move massage chair

**Caution**

- Don't move chair when it's working to avoid accidents or damage

**How to move**

- Binding the cables and put in the seat to avoid damage when moving.
- If you plump the chair, it may damage the inner parts of the chair.
- Don't use the castor if the floor is wooden or other easy damaged material. It will need 2 or more persons lift the chair.
- Don't shake the leg, or it may cause damage on the chair.
- Make sure unplug the power and plug can't touch the floor (It's better to let the chair in standing status to avoid the back crashing the floor)



**Normally**

- One person lift the leg to the limited position and continuing lifting to make the gravity falls

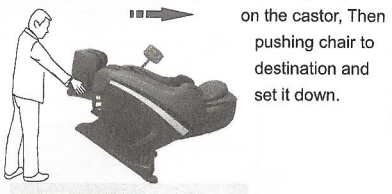

on the castor, Then pushing chair to destination and set it down.

- Please hold the footrest to move the chair as shown in the picture in case any scratches on the leatherette.

- Two persons hold the two arms, lift and moving the chair to destination.

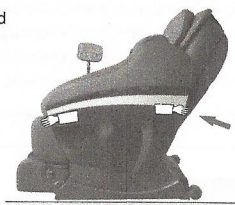

Adjustment before massage

**Before adjustment**

- Please make sure the massage head in right position, then sit down (to avoid massage roller hit you head)



**Shoulder testing**

When test shoulder height, if can't find the shoulder, the chair has acquiescent height. Correct pose: Sit down and put the back closely to the backrest of the chair, user's head should lean back on the back head pad, the correct pose can get exact upper body height. During body height testing period, the massage roller will softly roll to the bottom of the backrest before coming out to maximum, then go to the top to test shoulder height.



- Avoid testing out wrong shoulder position, which makes you can't get good massage.

**Warning:** The removable pad with heat function which is zippered on the back must be removed from the back cushion to avoid hurt or accident when the back massage machine is working.

**Kind suggestion**

- When you feel the intensity isn't strong, take off the pillow or cushion.
- Because the chair is heavy, it may ruin your floor in long time setting. Please put a blanket or other soft things to protect your floor.

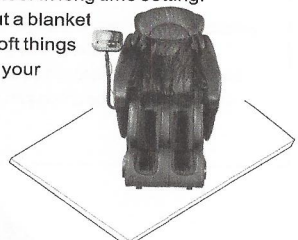

VFD remote control usage method

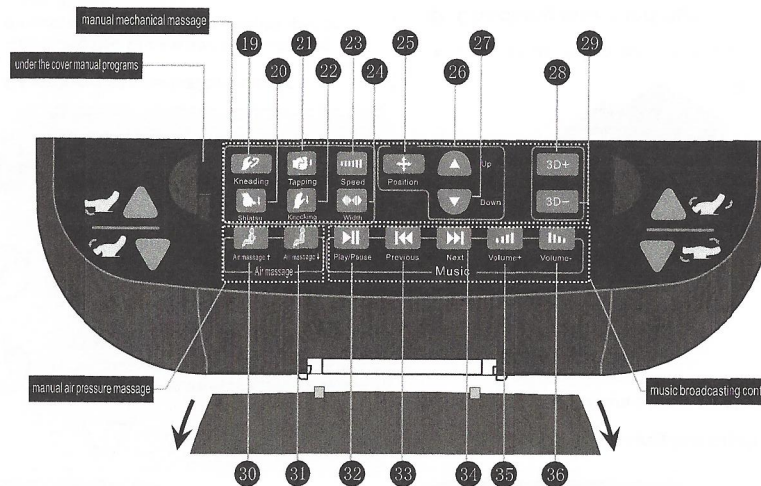
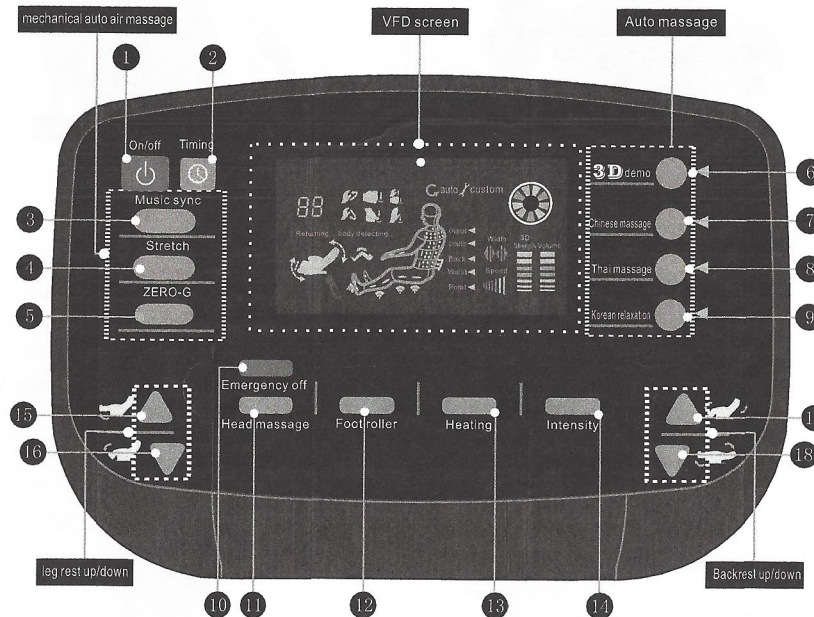



On/off

1. Turn on the power, press on/off key, the chair is in standby mode, auto/manual operation is available, press any key to test upper body height and the backrest will accordingly recline, after that, full automatic mode is available, press same key once again, massage operation will stop, the massage machine will move up to the top of the backrest.



Timing

2. After pressing on/off key, default time is 20mins, press this key to choose setting time from 10 to 30mins, demo time is 5mins, when demo time is up, the massage machine will move up to the top of the backrest, the backrest of the chair will sit up to original status.



Music sync

3. Press "Music sync" key, massage intensity of kneading and knocking will follow volume's and tune's adjustment, air massage is still working at the same time, press the key once more, music sync function is closed.



Stretch

4. Press "stretch" key to start air pressure massage, back massage is still working at the same time, press the key once more, air pressure massage will be closed.



ZERO-G

5. Press "ZERO-G" key, the chair is in zero gravity pose, press the key again, the backrest will recline to maximum, press it once more, the backrest will sit up.



3D demo

6. Press "3D demo" key to experience 3D back massage, press it again to stop 3D demo.



Chinese massage

7. Press "Chinese massage" to experience Chinese medical therapy style massage, press it again to close the function.



Thai massage

8. Press "Thai massage" key to experience Thai style massage, press it again to close the function.



Korean relaxation

9. Press "Korean relaxation" key to experience Korean style massage, press it again to close the function.



Emergency off

10. Press "Emergency off" key, all of the function will stop.



Head massage

11. Press "head massage" to start head air pressure massage while back massage can also be available, press the key again to close the function.



Foot roller

12. During air pressure massage, press "Foot roller" key to experience roller massage in the foot area, press the key again to close the function.



Heating

13. During air pressure massage, press "Heating" key to experience heat in the lower back, heating includes "high, middle, lower and close" four levels at your option.



Intensity

14. Press this key to choose different air intensity.



15. Keep pressing the key, the legrest will go up; release the key, the legrest position will stay in the locked position.



16. Keep pressing the key, the legrest will go down; release the key, the legrest position will stay in the locked position.



17. Keep pressing the key, the backrest will sit up while the legrest will go down, release the key, the backrest and the legrest will stay in the locked position.



18. Keep pressing the key, the backrest will recline while the legrest will go up, release the key, the backrest and the legrest will stay in the locked position.



Kneading

19. Press "Kneading" key to experience kneading massage, press the key again, the function is closed, kneading can also be combined with other massage functions.



Shiatsu

20. Press "Shiatsu" key to experience shiatsu massage; press the key again, shiatsu massage will be closed.



Tapping

21. Press "Tapping" key to experience tapping massage; press the key again, tapping massage will be closed.



Knocking

22. Press "Knocking" key to experience knocking massage; press the key again, knocking massage will be closed.



Speed

23. In manual mode, during kneading, tapping, music sync, knocking massage, press "Speed" key to adjust three shifts massage speed.



Width

24. In manual mode, during tapping, shiatsu and knocking massage, press "Width" key to adjust massage arm width between massage rollers.



Position

25. Press "Position" key to choose massage position at full back, shoulders, back, lower back and fixed point.



Up

26. At "fixed point" massage, press "Up" key to slightly adjust massage roller position.



Down

27. At "fixed point" massage, press "Down" key to slightly adjust massage roller position.



3D+

28. In manual mode, keep pressing "3D+" key to push massage machine forward to enjoy more 3D feeling; release the key, the massage machine will stay in the adjusted 3D position.



3D-

29. In manual mode, keep pressing "3D-" key to push massage machine backward to enjoy less 3D feeling; release the key, the massage machine will stay in the adjusted 3D position.



Air massage ↑

30. Press "Air massage" ↑ to start/close air pressure in the arms, lower back and seat area.



Air massage ↓

31. Press "Air massage" ↓ to start/close air pressure in shanks and foot area.



Play/Pause

32. Press "Play/Pause" key to enjoy music; press the key again, music is closed.



Previous

33. Press "Previous" key to enjoy previous music.



Next

34. Press "Next" key to enjoy next music.



Volume+

35. Press "Volume+" key to increase music volume.



Volume-

36. Press "Volume-" key to reduce music volume.

VFD screen illustration

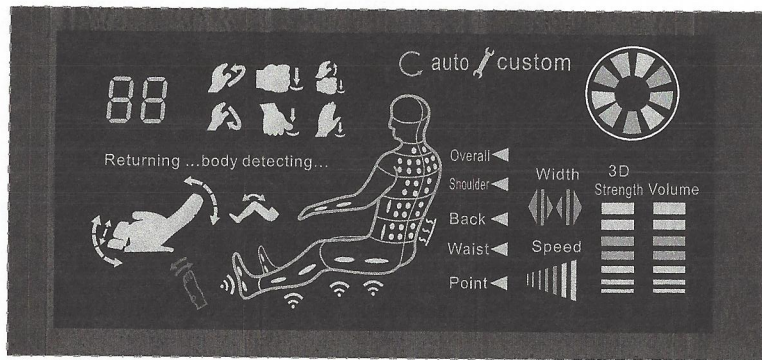

88 Digital display: When Standby it shows "==" ,when the power is on, it shows balance working time.

Massage Operation

Function		Kneading	Automatic Custom	In automatic mode, orange, green, blue shows in turn.
		Tapping		
		Pressing		
		Knocking		
	Width Intensity			backrest up/down legrest up/down

Returning...  
It means massage time is over, or the chair is restoring.

Body-detecting...  
It means the chair is detecting and scanning body shape.

Leg stretch  
This means leg stretching is on.

air pressure position

4- roller massage position

intensity of air pressure massage

Heat on the lower back

Roller and air massage on the foot area

- Overall ◀
- Shoulder ◀
- Back ◀
- Waist ◀
- Point ◀

ON/OFF

**Step 1. Turn on power**

- Put controller plug to A hole.
- Put one end of power line to B hole.
- Put electricity plug into socket.
- Turn on the switch under the massage chair on the back, controller goes into standby "==" at the same time. If no button pressed in 2 minutes, the chair goes into low-power consuming and standby status.
- Press ON/OFF on controller.

Massage Operation

Step 2. Massage

- Choose massage function as per control operation instruction. As for massage method, refer to Controller Usage.
- When time is up, massage turns off, but chair position remains, showing standby status "==" , if no button pressed in 2 minutes, the chair goes into low-consuming status.

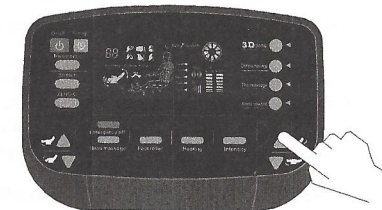

**Step 3. Turn off the power**

- Press on/off key on the control to turn off the massage machine and it will restore automatically.
- Turn off power switch on the bottom of the chair after the rollers stay at storage position.
- Unplug the power from the socket.

**Warning**

Before Using, please remove the pillow mat and back mat to check the backrest and other parts, make sure they are complete, if a damage is found, please unplug the electricity and ask aftersales for help.

**Caution**

- Before Sitting, make sure the chair (including armrest, legrest, backrest and seat slit) has no foreign material.
- Make sure the chair is in storage position before sitting in.
- When using the chair, please don't stand on it.

## Function illustration

## ● Backrest down

Press "DOWN" key on the control, the backrest will go down and legrest will go up simultaneously. Release this key; the backrest and legrest will be fixed at locked angle.



## ● Backrest up

Press "UP" key on the control, the backrest will go up and legrest will go down simultaneously. Release this key; the backrest and legrest will be fixed at locked angle.

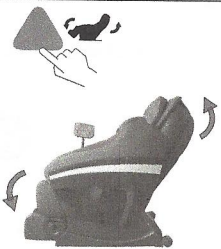

## ● Legrest up

Press legrest "UP" key on the control, the legrest will go up slowly. Release this key, the legrest will be fixed at locked angle.



## ● Legrest down

Press legrest "DOWN" key on the control, the legrest will go down slowly. Release this key, the legrest will be fixed at locked angle.



## ● Legrest extend and retract

Legrest can extend or retract within a range of 200mm.

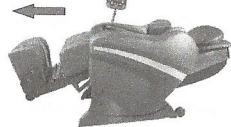

## ● Arm massage and Shoulder massage

Put arms between arm and shoulder airbags before the embedded airbags filled with air. Press key to enjoy arm and shoulder massage.



## ● Head massage

Separate head massager can offer comfortable air massage on the head and relieve your head fatigue.



## ● Heat function

Heat on the lower back and additional movable pad, the additional movable pad must be removed from the back cushion when you need back massage, the pad should be used on your belly or leg area.

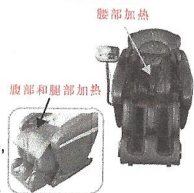

## ● Soft 3D Massage function

- Open the flip-cover on the controller, press Kneading, Tapping, Knocking to perform separate function, press intensity to set strength, press width to adjust wide, medium, narrow position.
- Press 3D- or 3D+ to adjust 3D massage machine to move forward and backward.



- The removable pad with heat function which is zipped on the back must be removed from the back cushion to avoid hurt or accident when the back massage machine is working.
- Please make sure there is nobody, no pet or nothing within permitted range for backrest and legrest to avoid any unexpected hurt or property loss.
- When you adjust the backrest, be careful with the gap between the backrest and armrest.
- When foot rest is bending the feet, don't stand up or getting off seat. Don't try to stop foot rest from working in case of getting hurt or damaging the chair.
- For more information, please refer to controller usage.

## Restorage of massage chair

- Make sure there is no people or pet or nothing within the range of backrest and legrest.



- Make the backrest and legrest return to restoring position by operating the relevant button (or press ON/OFF).

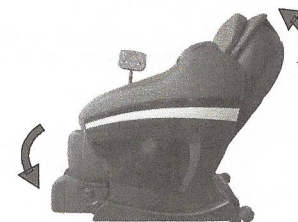

- After restoring, put the controller back to the controller holder.



- Put the back mat and pillow mat away on the backrest.

- Switch off power.

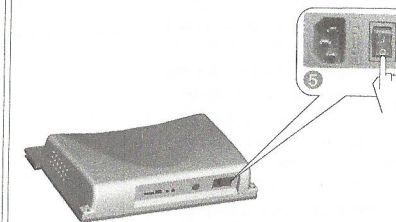

- unplug the electricity from the socket. (Attention: hold the right plug position)

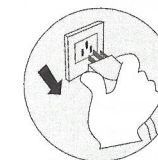

- Clean the chair if necessary.



## Attention

- After Using, press ON/OFF to end all the massage method and wait for restoration. Make sure to cut the electricity to avoid any unexpected hurt to children or pets.
- After using, turn off the power, unplug the electricity. Avoid moisture, dirt and aging of insulation in case of causing damage.

**Synthetic leather**

**General cleaning**

Clean with clean, soft and dry cloth slightly.



(chemical or medical cleaning products are forbidden)



**If leather is dirty**

- ① Dip soft cloth into 3-5% neutral detergent solution, squeeze it then clean the stain on the surface softly.
- ② Wash cloth, squeeze it and wipe the detergent.



- ③ clean it softly with dry cloth.
- ④ allow to dry  
(air blower is prohibited)

**Plastic parts**

- ① Dip cloth into neutral detergent, squeeze it and clean.
- ② Wipe with water-dipped but squeezed cloth.
- ③ Allow to dry.



**Clean the controller**

- ① Wipe with soft cloth after squeezing .
- ② Allow to dry.

Propellant, diluent or alcohol are prohibited



**Cloth material**

- ① Dip cloth into weak neutral detergent, squeeze it and clean the material surface.

(Diluent, gas, alcohol are prohibited)



- ② Brush the dirty parts with weak neutral detergent. (avoid excessive brushing)

※ Excessive cleaning may cause damage to cloth material.

- ③ Wipe with water-dipped but squeezed cloth
- ④ Allow to dry.



**About cleaning**

- Before cleaning, unplug the electricity, don't touch plug with wet hands.
- Make sure hands are dry when plugging to the socket.
- If failed to follow the mentioned instruction, one may get electric shock or burnt

Clean and maintenance

Miscellaneous

**FAQ and troubleshooting**

Trouble	Possible reason	Troubleshooting
The massage chair can't work after power is on.	Check if the control is on or not.	Open control switch
	Not choose massage function	Choose massage function
	Check whether the plug and socket in poor contact.	Make sure plug and socket are connected.
	Wire or plug has damaged.	Please ask manufacturer or appointed or authorized maintenance man for checking and replacement.
	The fuse burned out.	Replace fuse of same specification.
	Something wrong with inner circuit	Please ask appointed or authorized maintenance man for checking and repairing.
There is beep sound inside the massager while working.	It is sound of air pump, motor and mechanical parts.	Normal sound, no need to pay attention to it.
Different height of the left roller and right roller.	Massage rollers work on shifts.	Normal, no need to pay attention to it.
Sound suddenly becomes much louder while working.	Check if it is due to long time working.	Turn off the power to have the massager rest for over half an hour before next turn working.
	Inner parts fretted away due to long time work. It's normal	Please ask appointed or authorized maintenance man for checking and repairing.
Massage function suddenly stops while working.	Suddenly power-down	connect the electricity power again
	Setting time is up.	Turn off the power to have the massager rest for over half an hour before next turn working.
Neither the backrest nor the legrest can be lay down.	Check if there are any obstacles; the chair overloads; for the sake of safety, sometimes the massage machine may automatically stop working.	Remove the obstacles; turn off the power to have the massager rest for over half an hour before next turn working.
The chair can't return to its original position.	Excessive operation; setting time is up.	Please ask manufacturer or appointed or authorized maintenance man for checking and replacement.
Controller gives out heat	Caused by long time using	Stop using it, if it gives too much heat. Turn to assigned repair division for help.
Electric wire or plug give out heat	It may work overload	Turn off the power to have the massager rest for over half an hour before next round working.
	other abnormal case	Stop using, and ask appointed maintenance man for help.
Airbag doesn't work	Airpipes may be squeezed when installing.	reinstall the armrest and avoid squeezing pipe.
	The connector is not connected well	reinstall the armrest and connect the connector well.



Note: if above-mentioned reasons are not included, please turn off the power switch on the outside of the right armrest, unplug the power and contact your dealer or our company for repair or maintenance.

## Technical data

Name	Navigator Zero-gravity Space Capsule Massage Chair	Power (W)	280
Type	RK7803	NW/GW (kgs)	Main body: 106 / 121 Armrest: 27 / 34
Input voltage	<input type="checkbox"/> AC120V, 60Hz <input type="checkbox"/> AC220V, 50/60Hz <input type="checkbox"/> AC240V, 50Hz	Packing size (cm)	139X77X88(Main body packing) 106X44X95(armrest packing)
Safety design	I Calss		



*[Faint, illegible text, possibly bleed-through from the reverse side of the page.]*